

MODEL 441

Multi-Stage Alternator

- Replaces Mechanical Alternators
- User Selectable for:
 - Single Motor/Pump
 - Two Motor/Pump (duplex)
 - Three Motor/Pump (triplex)
 - Four Motor/Pump (quadraplex)
- Unit Remembers Which Motor/Pump Is Next During Power Loss
- First-On, First-Off Operation

DESCRIPTION

The **Model 441 Multi-Stage Alternator** is designed to control the operating sequence of multi-stage motor/pumping systems. It can also be used to maintain the desired level of pressure-on air compressor systems. Four motor select DIP switches located on the front panel allow the alternator to control a single-motor/pump, two-motor/pump, three-motor/pump or four-motor/pump system.

The Model 441 will assure that only the necessary motors/pumps are operating, and that the run time for each motor/pump is approximately equal. Motors are sequenced "first-on, first-off". If the motor/pumping demand requires only one motor/pump at a time, the alternator will start the next motor/pump in sequence each time an input switch is closed. Input switches may be float switches, pressure switches, flow switches, etc., as required by the application.

Potential uses for the Model 441 include water supply systems, sewage disposal plant systems, storage tank filling systems, air compressor systems, irrigation and water recycling systems.

DIMENSIONS

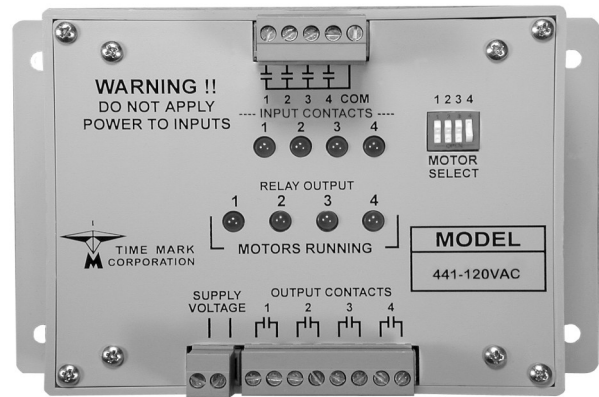
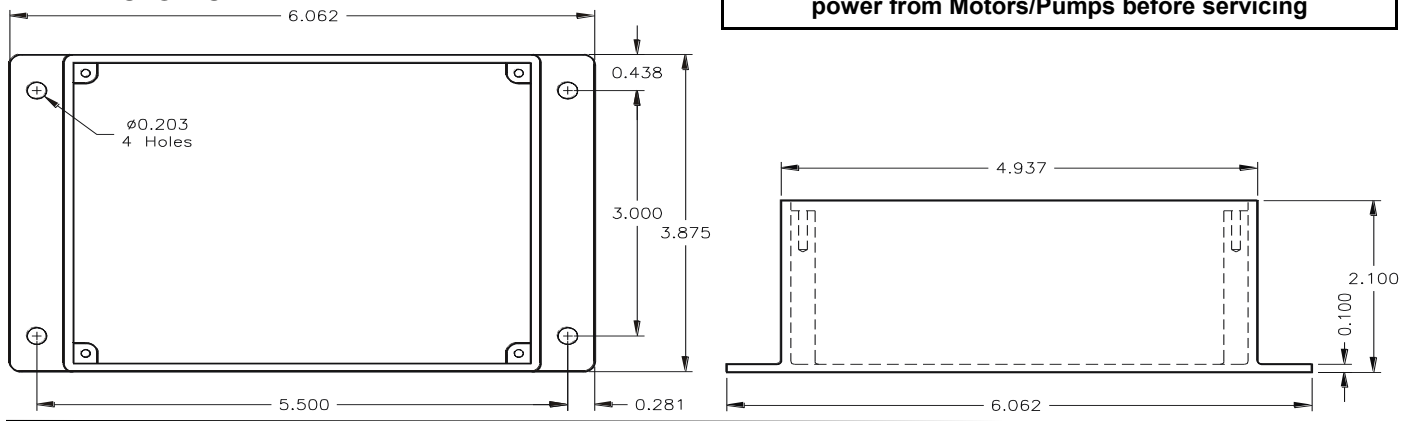

SPECIFICATIONS

MODEL	441-120	441-240
Input Voltage	120VAC +/- 10% 50/60Hz	240VAC +/- 10% 50/60Hz
Power Consumption	6.0 watts max.	
Transient Protection	2500 VRMS for 10ms	
Delay Between Relay Operations	5 seconds	
Output Contact Rating	SPST 5A at 240VAC or 5A at 30VDC resistive	
Input Contact Requirement	0.001 amp at 12VDC	
Expected Relay Life	Mech: 50 million operations Elec: 100,000 ops at rated load	
Operating Temperature	- 20° to +140° F	
Humidity Tolerance	0 - 97% w/o condensation	
Enclosure Material	ABS plastic	
Weight	1.0 lbs.	

Motor/Pump Select Switch

OFF (open)	Motor/pump disabled (unit will not try to use that motor)
ON (closed)	Motor/pump enabled (unit will operate relay for motor as needed)
The Model 441 is not a personal safety device. Remove power from Motors/Pumps before servicing	



TIME MARK
CORPORATION

11/2011
© 2011 TIME MARK CORPORATION

TIME MARK is a division of  AEMT, Inc.

MODEL 441 Multi-Stage Alternator

READ ALL INSTRUCTIONS BEFORE INSTALLING, OPERATING OR SERVICING THIS DEVICE.
KEEP THIS DATA SHEET FOR FUTURE REFERENCE.

GENERAL SAFETY

POTENTIALLY HAZARDOUS VOLTAGES ARE PRESENT AT THE TERMINALS OF THE MODEL 441.
ALL ELECTRICAL POWER SHOULD BE REMOVED WHEN CONNECTING OR DISCONNECTING WIRING.
THIS DEVICE SHOULD BE INSTALLED AND SERVICED BY QUALIFIED PERSONNEL.

Installation Instructions

INSTALLATION

Switch Inputs			
Input 1	First level input	Input 3	Third level input
Input 2	Second level input	Input 4	Fourth level input
COM	Supply voltage output to switches 12VDC		
** DO NOT APPLY VOLTAGE TO SWITCH INPUTS **			

Mount the Model 441 in an appropriate enclosure or panel.

Do not apply power until all other connections are made.

Connect the input switches (float, pressure, etc.) to the terminals marked INPUT CONTACTS.

One side of each input switch is connected to the common terminal; the other side should be connected to the input terminals, starting with terminal 1.

Terminal 1 will be the first selected for either the pump up or the pump down application. See the TYPICAL APPLICATION diagram.

Connect the control circuits of the pumps or motors to be alternated to the terminals marked OUTPUT CONTACTS.

Connect AC power connections to the terminals marked Supply Voltage.

ADJUSTMENT

Set the motor select DIP switches to the ON position, for every Motor/Pump connected to the Model 441 you wish to enable.

If a pump or motor must be removed from service, set the DIP switch to OFF for that motor/pump AND remove power from the motor/pump.

PUMP DOWN APPLICATION

In a "Pump Down" application, the switches are normally-open. As the liquid level rises, the number 1 level switch closes, turning on the first pump. If the level continues to rise, additional pumps are turned on.

As the level drops, the pumps or motors are turned off on a first-on/first-off basis. When the low level switch opens, the Model 441 alternates to the next pump for the next operating cycle. Switch number 1 determines when alternation occurs.

PUMP UP APPLICATION

In a "Pump Up" application, the switches are normally-closed. When the reservoir is full, the switches will be open. As the liquid level drops the number 1 level switch closes, turning on the first pump. If the level continues to drop, additional pumps are turned on.

When the level rises above the number 1 switch, the switch opens, turning off the pump. The Model 441 then alternates to start the next pump in line for the next operating cycle. The number 1 switch determines when alternation occurs.

WARRANTY

This product is warranted to be free from defects in materials and workmanship for one year. Should this device fail to operate, we will repair it for one year from the date of manufacture. For complete warranty details, see the *Terms and Conditions of Sales* page in the front section of the Time Mark catalog or contact Time Mark at 1-800-862-2875.

TYPICAL APPLICATION

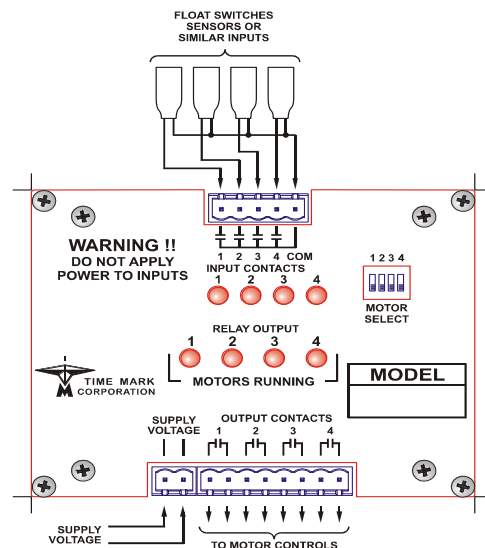

TIME MARK
CORPORATION

11/2011

© 2011 TIME MARK CORPORATION

TIME MARK is a division of  AEMT, Inc.